



MODEL: HR9-12

NO.: 302010005-00077



**Plane Chart:**

Unit:(mm) Terminal type:(F2)

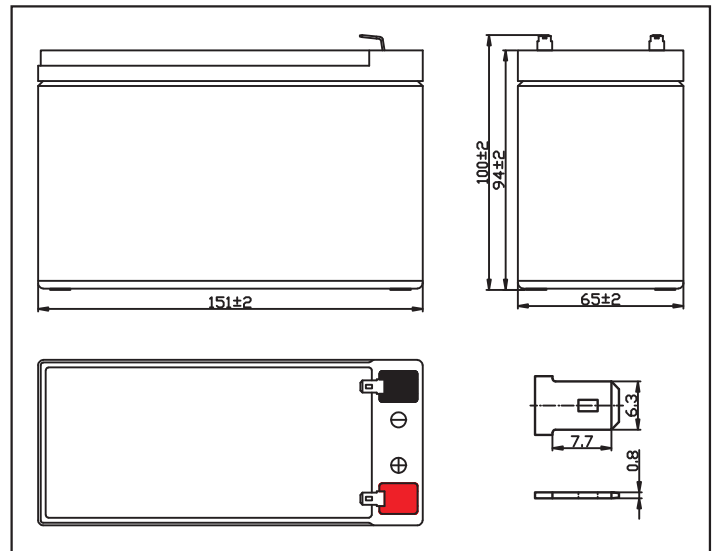

**Parameter Chart:**

Volts		12V	
Capacity(25°C)	20 hours rate (0.45A)	9Ah	
Discharge Current Testing (25°C)	20 I <sub>20</sub> rate (9A,27min)	34min	
	60 I <sub>20</sub> rate (27A,7min)	8min	
Internal Resistance	Full Charged Battery 25°C	18mΩ	
Capacity Affected By Temperature	40°C	104%	
	25°C	100%	
	0°C	83%	
	-15°C	65%	
Residual Capacity (25°C)	Capacity After 3 Months Storage	91%	
	Capacity After 6 Months Storage	82%	
	Capacity After 12 Months Storage	65%	
Charge (Constant Voltage)	Cycle (25°C)	Initial Charging Current Less Than 2.7A Voltage 14.5~14.9V	
	Float (25°C)	Charge Voltage 13.6~13.8V	
Weight (Approx)		2.40Kg	

**Residual Capacity**

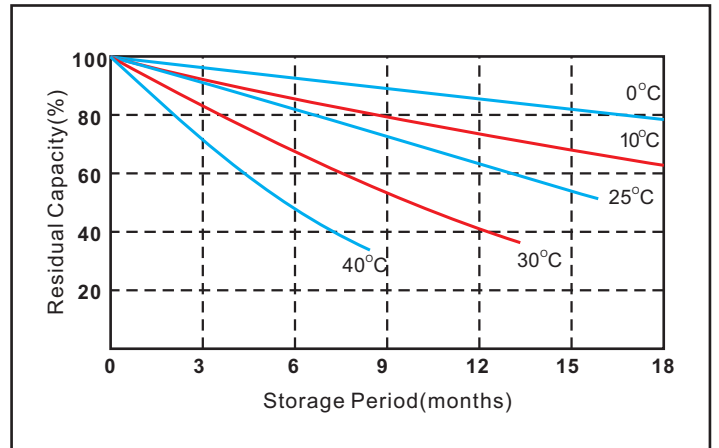

**Discharge Current 25°C**

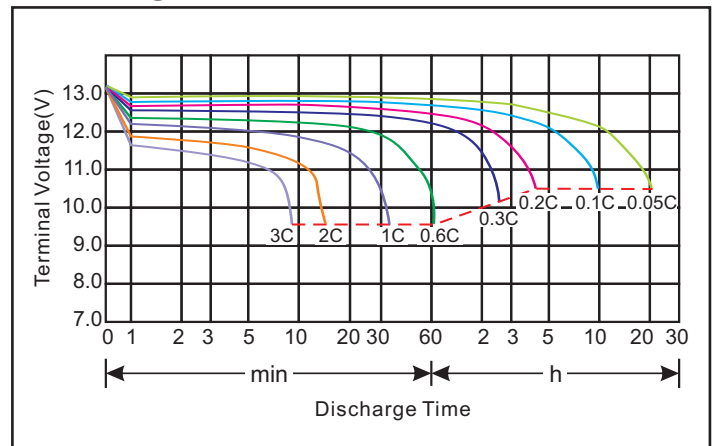

★The above are average and data obtained from the first 3 charge/discharge cycles. These are not minimum values.

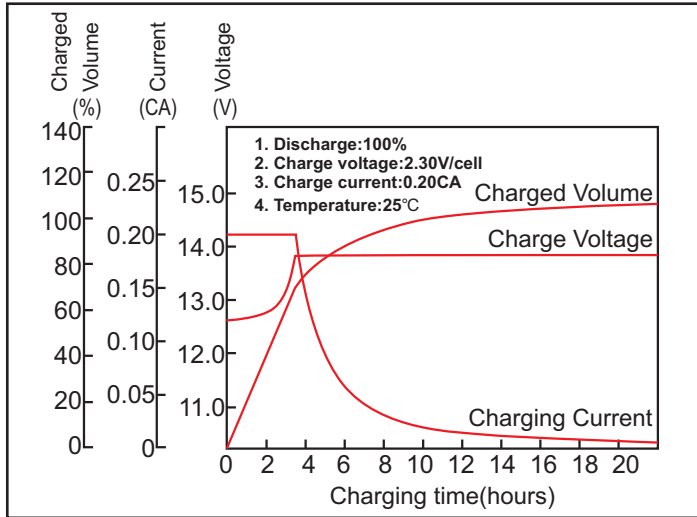
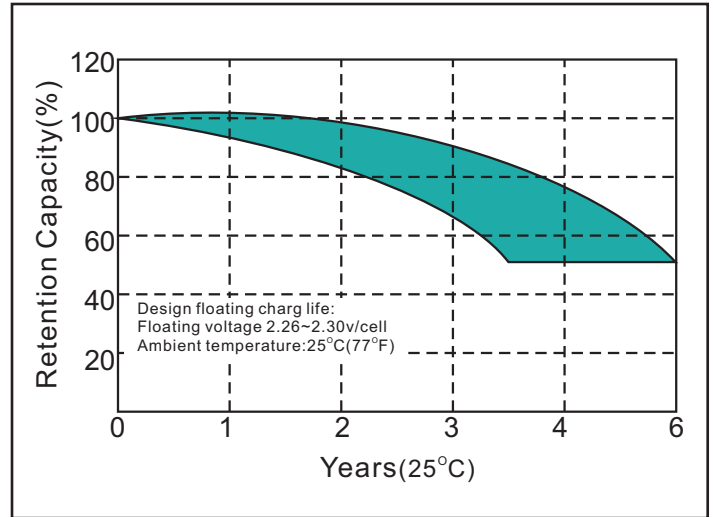
**Constant voltage charging characteristics**

**Float Life**

**Constant Current Discharge Characteristics (A, 25°C)**

F.V/Time	5min	10min	15min	30min	60min	2h	3h	5h	8h	10h	20h
9.60V	38.2	23.8	18.2	10.3	5.81	3.26	2.35	1.51	1.00	0.81	0.45
10.2V	34.6	22.7	17.1	10.0	5.69	3.17	2.32	1.49	0.99	0.80	0.44
10.5V	33.2	21.6	16.6	9.7	5.56	3.12	2.28	1.48	0.98	0.79	0.43
10.8V	31.3	20.3	16.1	9.5	5.47	3.07	2.25	1.46	0.97	0.78	0.43

**Constant Current Discharge Characteristics (Watt, 25°C)**

F.V/Time	5min	10min	15min	30min	60min	2h	3h	5h	8h	10h	20h
9.60V	412.6	259.4	200.2	115.4	66.3	37.5	27.3	17.70	11.82	9.56	5.37
10.2V	380.6	252.0	191.5	113.0	64.9	36.5	26.9	17.47	11.71	9.44	5.24
10.5V	368.5	241.9	187.6	110.6	63.9	36.5	26.7	17.50	11.69	9.40	5.12
10.8V	350.6	229.4	183.5	109.3	62.9	35.9	26.3	17.26	11.54	9.28	5.12

**Capacity Factors With Different Temperature**

Battery Type		-20°C	-10°C	0°C	5°C	10°C	20°C	25°C	30°C	40°C	45°C
Battery	12V	50%	70%	83%	85%	90%	98%	100%	102%	104%	105%

★The above are average and data obtained from the first 3 charge/discharge cycles. These are not minimum values.